

# AxiWin



500W LED Lighting

#### Designed for use in:

- Ships
- Light Towers
- Agricultural machines
- Road work machines
- Crushers
- Drag lines
- Excavators
- Flood lighting
- Gantry cranes
- Large open areas
- Processing plants
- Warehouses
- Workshops
- Harbors
- Road intersections
- ROM bins

AXIWIN's (DCB) DCB95 series is designed and engineered to produce the brightest industrial LED lamp in the world. This has been achieved by utilising the lowest energy consumption mini-mising the impact on our sensitive environment.

The Dutch designed world class product delivers matchless high efficient light output. The housing has been tested in the harshest environments in the world, The engineering of the housing has allowed for supreme heat dissipation to maximise the performance of the highest grade LED's in its market. Current testing claims the light output on the DC95 series up to 2 times brighter than any other lamp on the market utilising the same power consumption. A large range of light angle available for the DC95 series guarantees each and every light delivered will be fit for its purpose.

Every component has been strategical hand selected and tested to maximise performance and reliability which is reflected in DCB's warranty. At DCB we not only manufacture and assembly our range we provide technical support 24/7 across the globe. DCB believe partnering with our clients allows growth and sustainability leading into long term relationships.

## AxiWin

[www.axiwin.com](http://www.axiwin.com)

E-Mail: [sales@axiwin.com](mailto:sales@axiwin.com)  
Tel: 0031180531616

Contact us for the Latest information.





## Specifications

### Product

Brand Axiwin  
Model DCB95-500AC

### Optical Specifications

Light Output Lamp 65,823 lm  
Light Output (raw leds) 77,800 lm  
Efficiency 145 lm/W  
CRI >70  
Available Light Angles 8° - 13° - 38° - 69° - 46x14° - 106x29°

### Available beam options:

White 6500K  
Neutral White 4000K  
Warm White 2700K

### Electrical specifications

Power Consumption Lamp 475W (inc driver 500W)  
Voltage Range 90-305V AC / 127-431VDC  
Current draw 240VAC = 2.1A

### Environmental

IP Rating IP67  
Impact Rating IK09  
Operation Temperature Range -30-+50°C  
Expected Life Span 50,000 Hours to 70% Brightness  
Material Lamp Body Aluminium Alloy,  
(Military Grade Alodine and E-Coating)  
Material Lamp Bracket High Tensile Strength Stainless Steel 316  
Material Front Cover UV Coated Polycarbonate  
Colour Titanium Grey  
Light Angle Adjustment +/- 240° in 30° steps  
Cable Length 2m

### Weight and Packaging

Lamp weight 16.6kg  
Bracket Weight 3.1kg  
Packaging Dimensions 570 x 505 x 165mm  
Packaging Weight 22.4kg

### Warranty

Warranty 3 Years

## Dimensions

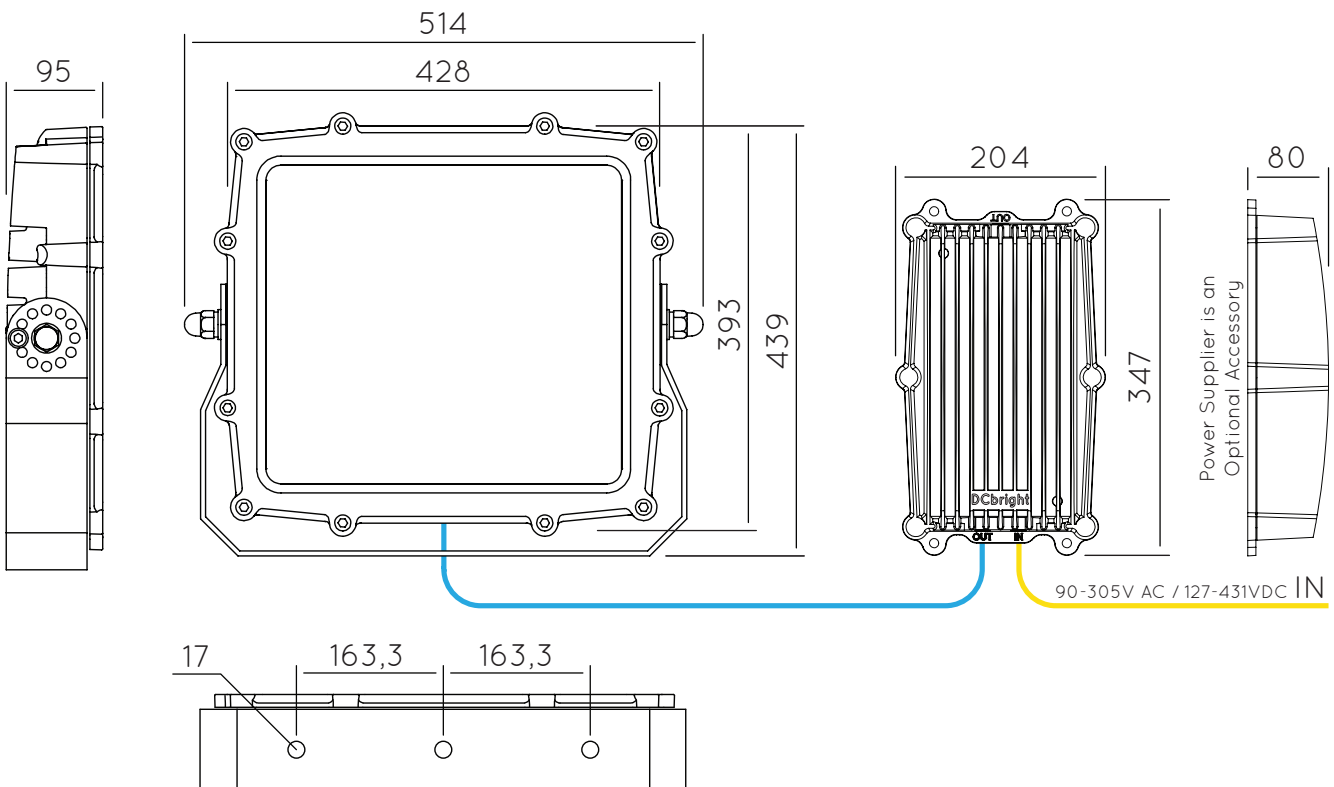

DCbright Power Supply will be available approximately mid 2016, Please contact us for more information.



### Power Stability

Driver Efficiency Graphs

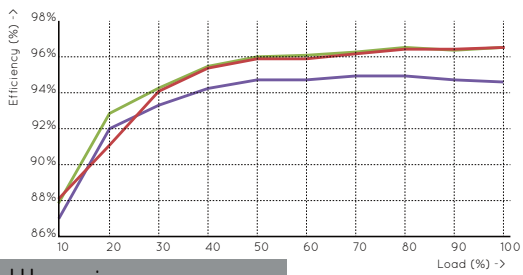

Power Factor

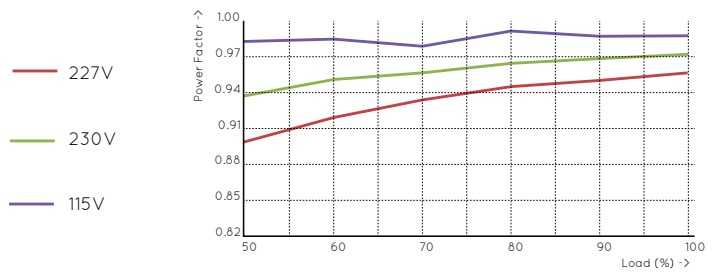

### Illuminance

