



310W LED Lighting

Designed for use in:

- Ships
- Light Towers
- Agricultural machines
- Road work machines
- Crushers
- Drag lines
- Excavators
- Flood lighting
- Gantry cranes
- Large open areas
- Processing plants
- Warehouses
- Workshops
- Harbors
- Road intersections
- ROM bins

AXIWIN (DCB) DCB95 series is designed and engineered to produce the brightest industrial LED lamp in the world. This has been achieved by utilising the lowest energy consumption mini-mising the impact on our sensitive environment.

The Dutch designed world class product delivers matchless high efficient light output. The housing has been tested in the harshest environments in the world, The engineering of the housing has allowed for supreme heat dissipation to maximise the performance of the highest grade LED's in its market. Current testing claims the light output on the DC95 series up to 2 times brighter than any other lamp on the market utilising the same power consumption. A large range of light angle available for the DC95 series guarantees each and every light delivered will be fit for it purpose.

Every component has been strategical hand selected and tested to maximise performance and reliability which is reflected in DCB's warranty. At DCB we not only manufacture and assembly our range we provide technical support 24/7 across the globe. DCB believe partnering with our clients allows growth and sustainability leading into long term relationships.



Specifications

Product

Brand AXIWIN
Model DCB95-300

Optical Specifications

Luminous Flux (output lumen) 33,981-44,943 lm (2700K - 6500K)
Luminous Flux (LED lumens) 51,910 lm
Efficiency 145 lm/W
CCT 2700K - 8300K
CRI >70
Available Light Angles 8° - 13° - 38° - 69° - 46x14° - 106x29°

Electrical specifications

Power Consumption Lamp 310W
Nominal Voltage 24V
Voltage Range 21-48V
Cable Type PVC 2x2mm²
Cable Diameter 7.5mm
Cable Length 2m

Environmental

IP Rating IP67
Impact Rating IK09
Operation Temperature Range -30-+50°C
Expected Life Span 50,000 Hours to 70% Brightness
Material Lamp Body Aluminium Alloy, (Military Grade Alodine and E-Coating)
Material Lamp Bracket High Tensile Strength Stainless Steel 316
Material Front Cover UV Coated Polycarbonate
Light Angle Adjustment +/- 240° in 30° steps

Weight and Packaging

Lamp weight 16.6kg
Bracket Weight 3.1kg
Packaging Dimensions 570 x 505 x 165mm
Packaging Weight 22.4kg

Warranty

Warranty 3 Years

Dimensions

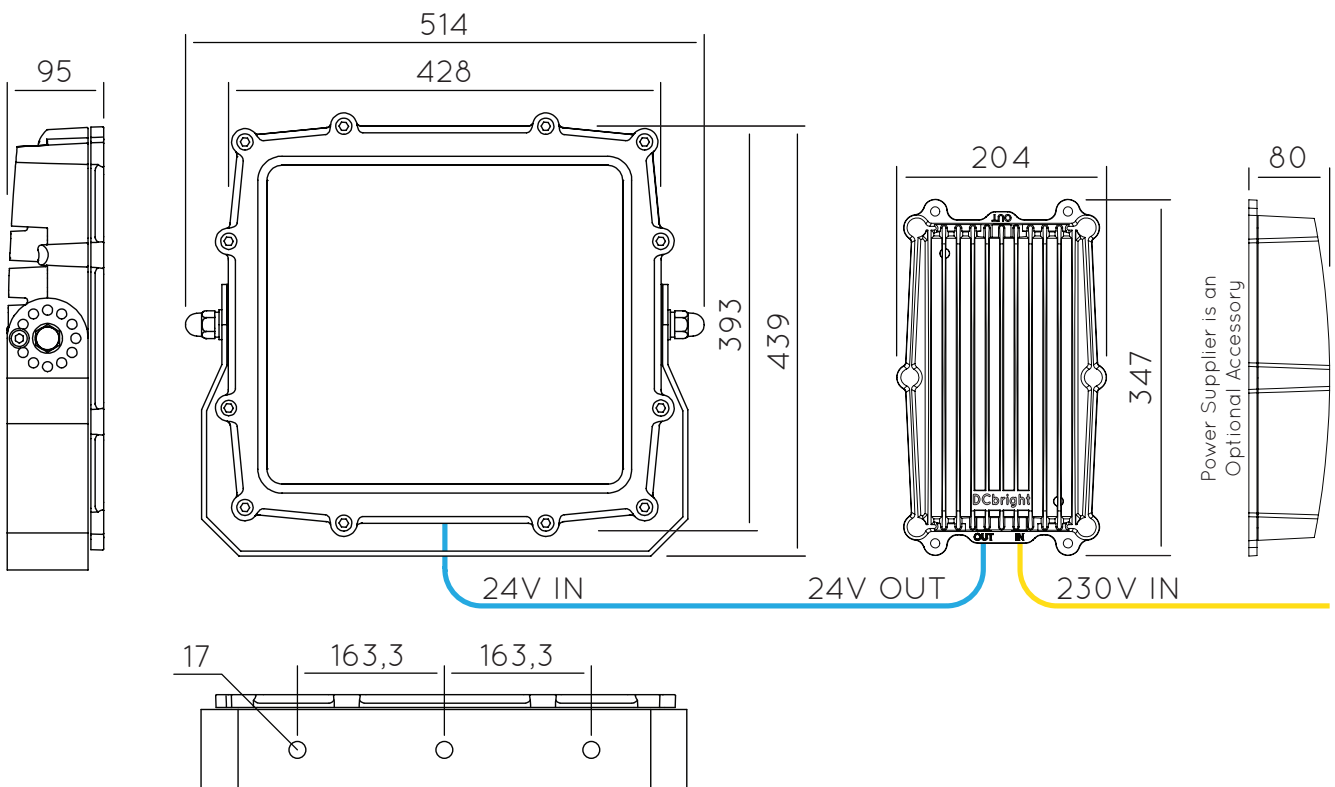

AXIWIN DCB will be available approximately mid 2016. Please contact us for more information.



Power Stability

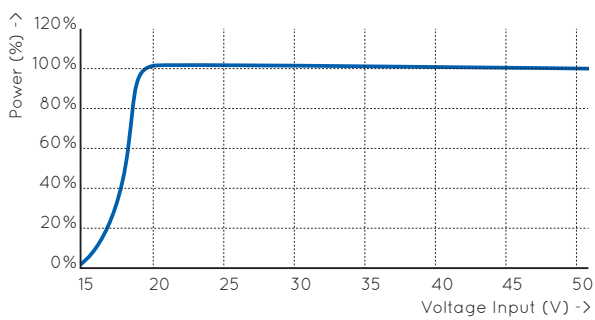

Connection

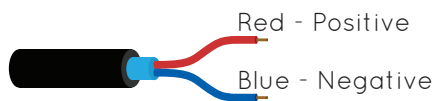

Illuminance

